



LEO EC
S2 | S3 | S3 NP
L2 | L3 | L3 NP
XL2 | XL3 | XL3 NP

Fan heater

Technical and commissioning documentation

TABLE OF CONTENTS

| | | |
|--|-----------------------|-----------|
| TECHNICAL DOCUMENTATION | EN | 4 |
| 1. IMPORTANT INFORMATION | | 4 |
| 2. APPLICATION | | 5 |
| 3. TECHNICAL DATA | | 6 |
| 4. INSTALLATION | | 9 |
| 4.1 | INSTALLATION-BRACKET | 9 |
| 4.2 | ASSEMBLY INSTRUCTION | 9 |
| 4.3 | Z-PROFILES (OPTIONAL) | 9 |
| 5. CONNECTION DIAGRAMS | | 10 |
| 5.1 | HMI EC CONTROLLER | 10 |
| 5.2 | DRV M CONTROL MODULE | 10 |
| 5.3 | HYDRAULIC CONNECTION | 11 |
| 6. START-UP AND OPERATION | | 11 |
| 7. SERVICE AND WARRANTY TERMS | | 13 |
| 8. CONFORMITY WITH WEE DIRECTIVE 2012/19/UE | | 13 |

1. IMPORTANT INFORMATION

We have made every effort to make this manual as easy to understand as possible. However, if you have any difficulties, problems or questions, please contact FLOWAIR support at: info@flowair.pl

Also visit our website www.flowair.pl where you will find mounting tips.

In this manual you will find important safety information and tips marked as below:



Dangerous practices which may result in serious injury or death. Read all warnings before starting work.



Unsafe practices which, if not avoided, may result in damage to property or minor injuries. Before starting work, read all cautions.



Useful tips for the user and installer.

IMPORTANT SAFETY INFORMATION:



1. Before installing, connecting, starting up, using and maintaining the device, please read this manual completely.
2. After receiving the product, check that it has not been damaged during transport. If the product appears to be damaged, DO NOT START TO MOUNT THE DEVICE; instead, you must immediately report the damage to the carrier.
3. The device must be mounted in a stable way and in accordance with the instructions, in a place that can be easily accessed, thus ensuring the possibility of carrying out repairs and routine maintenance, as well as allowing easy and safe disassembly of the device.
4. The stability and durability of installation of the device depends on the structure of the building (walls and ceilings). The person performing the assembly should take these conditions into account when mounting the device.
5. The technical documentation should be kept in a safe place, easily accessible to the user and service technician.
6. The nameplate is located next to the cable glands on the top of the device.
7. Always test the operation of the device after installation.



1. The power connection shall be performed only by an authorized person.
2. The device requires periodic inspections in accordance with the instructions in this manual.
3. Do not hang/put pressure on the device.
4. Do not place any objects on the device or hang anything on the connection stubs.
5. The product should be stored and assembled out of the reach of small children.
6. The device is dedicated to working indoors with a maximum air dustiness of 0.3 g/m³. The device has elements made of aluminum, copper and galvanized steel and cannot be used in a corrosive environment.
7. Equipment cannot be used in an environment where oil mist is present.
8. This equipment may be used by children that are at least 8 years old, by people with reduced physical and mental abilities and people with no experience and knowledge of the equipment, on condition that supervision or instruction regarding correct use of the equipment in a safe manner is provided and the possible threats are understood. The device cannot be used by children to play. Unattended children should not clean or maintain the equipment.



1. The device is powered by dangerous voltage. Always disconnect the device from the power supply before servicing or accessing its internal components.
2. Do not insert your fingers or any objects inside the device.
3. Do not cover the device.

2. APPLICATION

LEO EC fan heaters make up a decentralised heating system. The air streaming through the heat exchanger filled with hot water is warmed up. Fan heaters are used for heating large volume buildings: general, industrial and public buildings etc.

The casing of LEO EC heaters is made from extended polypropylene EPP.

The devices are designed for indoor use where maximum air dustiness does not exceed 0,3 g/m³. Units are built using copper, aluminum and galvanized steel. It is prohibited to install units in the areas where environment inside can causes in rusting. **The devices cannot be used in an environment where there is oil mist.**

Water heat exchanger could be supplied by water or glycol solution up to 60% (especially when operating at temperatures below 0°C). The heat exchanger tubes are made of copper. The feed medium should not cause corrosion of this material. In particular, the parameters as below should be provided.

| Parameter | Value |
|--------------------------------|--------------------------------------|
| pH | 7,5-9,0 |
| Content of impurities | free of sediments/particles |
| Total hardness | $[Ca^{2+}, Mg^{2+}]/[HCO_3^-] > 0.5$ |
| Oil and grease | <1 mg/l |
| Oxygen | <0.1mg/l |
| Bicarbonate, HCO ³⁻ | 60-300 mg/l |
| Ammonium | < 1.0 mg/L |
| Sulphide | < 0.05 mg/L |
| Chloride, Cl | <100 mg/l |

3. TECHNICAL DATA

LEO S2 EC | S3 EC | S3 NP EC

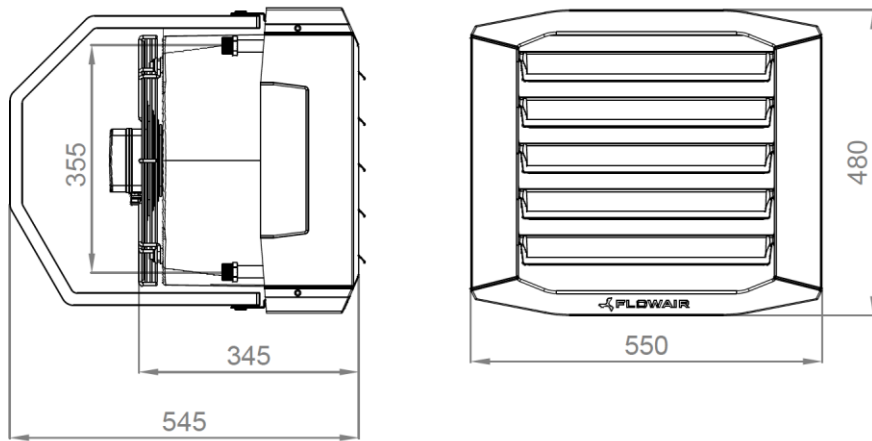

| | LEO S2 EC | | | | LEO S3 LEO S3 NP EC | | | |
|---------------------------------------|---------------------|------|------|------|-------------------------|------|------|------|
| | 10 | 8 | 6 | 4 | 10 | 8 | 6 | 4 |
| Gear [V] | 10 | 8 | 6 | 4 | 10 | 8 | 6 | 4 |
| Airflow* [m³/h] | 2000 | 1950 | 1400 | 900 | 1800 | 1750 | 1250 | 800 |
| Power supply [V/Hz] | 230/50 | | | | | | | |
| Max current consumption [A] | 0,75 | 0,71 | 0,34 | 0,15 | 0,73 | 0,71 | 0,33 | 0,15 |
| Max power consumption [W] | 99 | 96 | 44 | 17 | 96 | 94 | 43 | 17 |
| IP/ Insulation class | 44 / B | | | | | | | |
| Horizontal range** [m] | 14,0 | 13,5 | 10,0 | 6,0 | 12,5 | 12,0 | 8,5 | 5,5 |
| Vertical range*** [m] | 5,3 | 5,2 | 3,9 | 2,7 | 4,9 | 4,8 | 3,5 | 2,4 |
| Max heating water temperature [°C] | 120 / LEO S3 NP: 70 | | | | 120 / LEO S3 NP EC: 70 | | | |
| Max operating pressure [MPa] | 1,6 | | | | | | | |
| Connection | 1/2" | | | | | | | |
| Installation | Indoor | | | | | | | |
| Max working temperature [°C] | 60 | | | | | | | |
| Device mass [kg] | 9,0 | | | | 9,6 LEO S3 NP: 9,3 | | | |
| Mass of device filled with water [kg] | 10,2 | | | | 11,0 LEO S3 NP: 10,3 | | | |

* Airflow measured according to EN ISO 5801.

** Horizontal isothermal range for 0,5 m/s border air stream.

*** Vertical nonisothermal range for $\Delta T = 5^\circ\text{C}$ and for 0,5 m/s border air stream speed.

LEO L2 EC | L3 EC | L3 NP EC

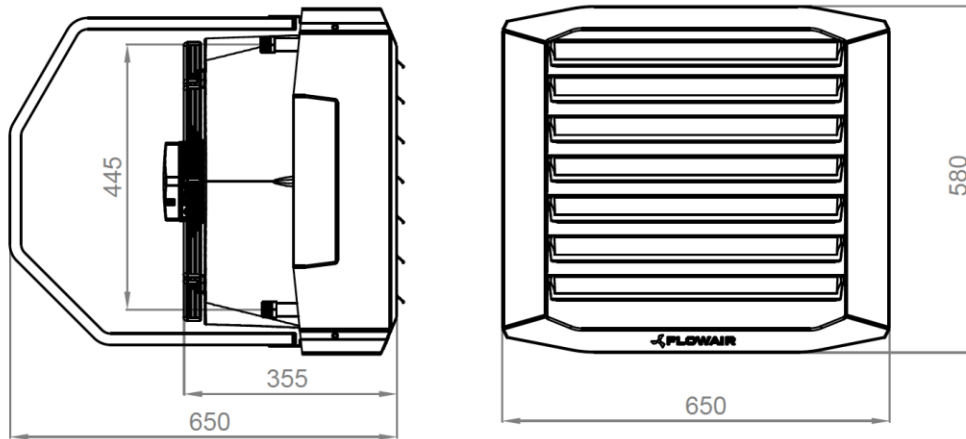

| | LEO L2 EC | | | | LEO L3 EC LEO L3 NP EC | | | |
|---------------------------------------|---------------------|------|------|------|--------------------------|------|------|------|
| | 10 | 8 | 6 | 4 | 10 | 8 | 6 | 4 |
| Gear [V] | | | | | | | | |
| Airflow* [m³/h] | 3550 | 2750 | 1950 | 1150 | 3200 | 2500 | 1750 | 1000 |
| Power supply [V/Hz] | 230/50 | | | | | | | |
| Max current consumption [A] | 1,15 | 0,61 | 0,35 | 0,22 | 1,14 | 0,61 | 0,35 | 0,22 |
| Max power consumption [W] | 255 | 128 | 57 | 22 | 253 | 126 | 56 | 22 |
| IP/ Insulation class | 44 / B | | | | | | | |
| Horizontal range* [m] | 20,0 | 15,0 | 10,5 | 6,5 | 18,0 | 14,0 | 9,5 | 5,5 |
| Vertical range** [m] | 7,0 | 5,6 | 4,2 | 2,7 | 6,4 | 5,2 | 3,8 | 2,4 |
| Max heating water temperature [°C] | 120 / LEO S3 NP: 70 | | | | 120 / LEO L3 NP EC: 70 | | | |
| Max operating pressure [MPa] | 1,6 | | | | | | | |
| Connection | 3/4" | | | | | | | |
| Installation | Indoor | | | | | | | |
| Max working temperature [°C] | 60 | | | | | | | |
| Device mass [kg] | 14,5 | | | | 16,0 LEO L3 NP: 14,5 | | | |
| Mass of device filled with water [kg] | 16,5 | | | | 18,7 LEO L3 NP: 16,8 | | | |

* Airflow measured according to EN ISO 5801.

** Horizontal isothermal range for 0,5 m/s border air stream.

*** Vertical nonisothermal range for $\Delta T = 5^{\circ}\text{C}$ and for 0,5 m/s border air stream speed.

LEO XL2 | XL3 | XL3 NP

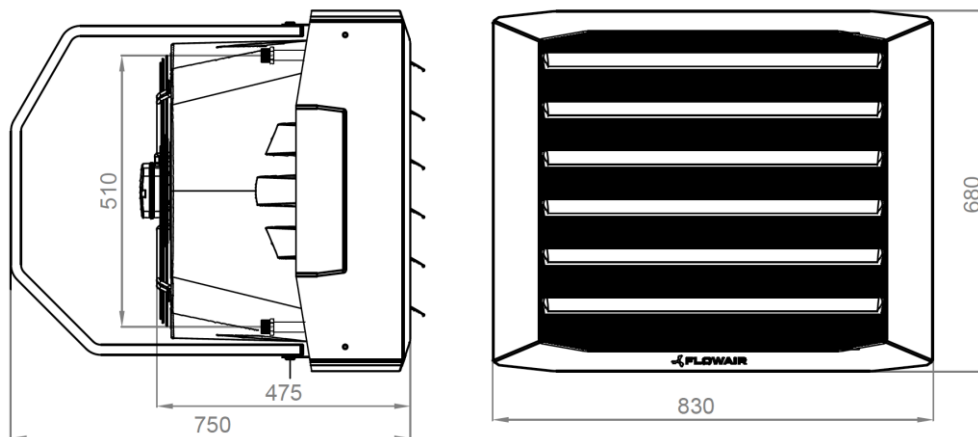

| | LEO XL2 EC | | | | LEO XL3 EC LEO XL3 NP EC | | | |
|---------------------------------------|------------|------|------|------|----------------------------|------|------|------|
| | 10 | 8 | 6 | 4 | 10 | 8 | 6 | 4 |
| Gear [V] | 10 | 8 | 6 | 4 | 10 | 8 | 6 | 4 |
| Airflow* [m³/h] | 6300 | 5050 | 3600 | 2200 | 5800 | 4600 | 3200 | 1680 |
| Power supply [V/Hz] | 230/50 | | | | | | | |
| Max current consumption [A] | 2,50 | 1,50 | 0,64 | 0,24 | 2,50 | 1,50 | 0,64 | 0,24 |
| Max power consumption [W] | 580 | 350 | 140 | 45 | 580 | 350 | 140 | 45 |
| IP/ Insulation class | 54 / F | | | | | | | |
| Horizontal range* [m] | 35,0 | 22,5 | 16,0 | 10,0 | 26,0 | 20,5 | 14,0 | 9,0 |
| Vertical range** [m] | 9,0 | 7,5 | 5,6 | 3,7 | 8,5 | 7,0 | 5,1 | 3,0 |
| Max heating water temperature [°C] | 120 | | | | 120 / LEO XL3 NP EC: 70 | | | |
| Max operating pressure [MPa] | 1,6 | | | | | | | |
| Connection | 3/4" | | | | | | | |
| Installation | Indoor | | | | | | | |
| Max working temperature [°C] | 60 | | | | | | | |
| Device mass [kg] | 23,2 | | | | 26,2 LEO XL3 NP: 25,8 | | | |
| Mass of device filled with water [kg] | 25,9 | | | | 30,3 LEO XL3 NP: 29,6 | | | |

* Airflow measured according to EN ISO 5801.

** Horizontal isothermal range for 0,5 m/s border air stream.

*** Vertical nonisothermal range for $\Delta T = 5^\circ\text{C}$ and for 0,5 m/s border air stream speed.

4. INSTALLATION

Fan heaters can be mounted to vertical or horizontal partitions in any position. During the montage, the minimal distances from the walls and ceiling must be kept.

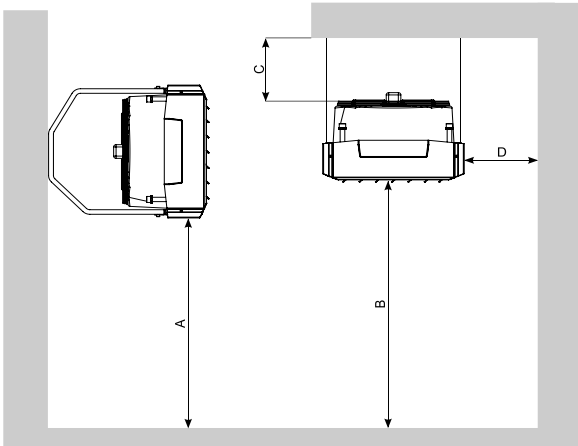

| | S2 EC | S3 EC S3 NP EC | L2 EC | L3 EC L3 NP EC | XL2 EC | XL3 EC XL3 NP EC |
|---|---------|-------------------|---------|-------------------|---------|---------------------|
| A | <3,0 | <3,0 | 2,5-8,0 | 2,5-8,0 | 2,5-8,0 | 2,5-8,0 |
| B | 2,5-6,0 | 2,5-6,0 | 2,5-8,5 | 2,5-8,0 | 2,5-9,5 | 2,5-9,0 |
| C | >0,3 | >0,3 | >0,3 | >0,3 | >0,3 | >0,3 |
| D | >0,5 | >0,5 | >0,5 | >0,5 | >0,5 | >0,5 |

4.1 INSTALLATION-BRACKET

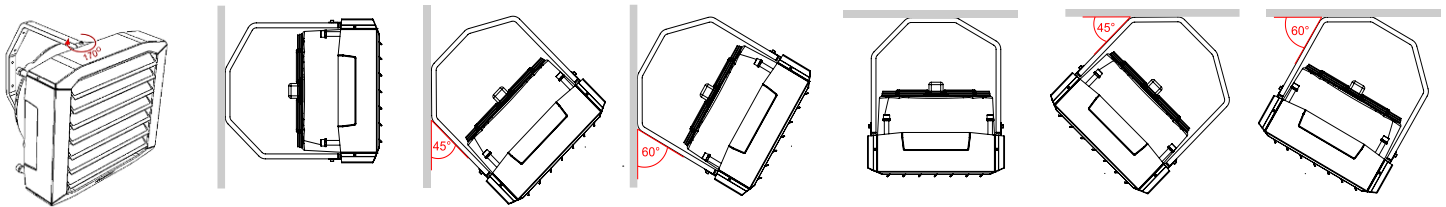

4.2 ASSEMBLY INSTRUCTION

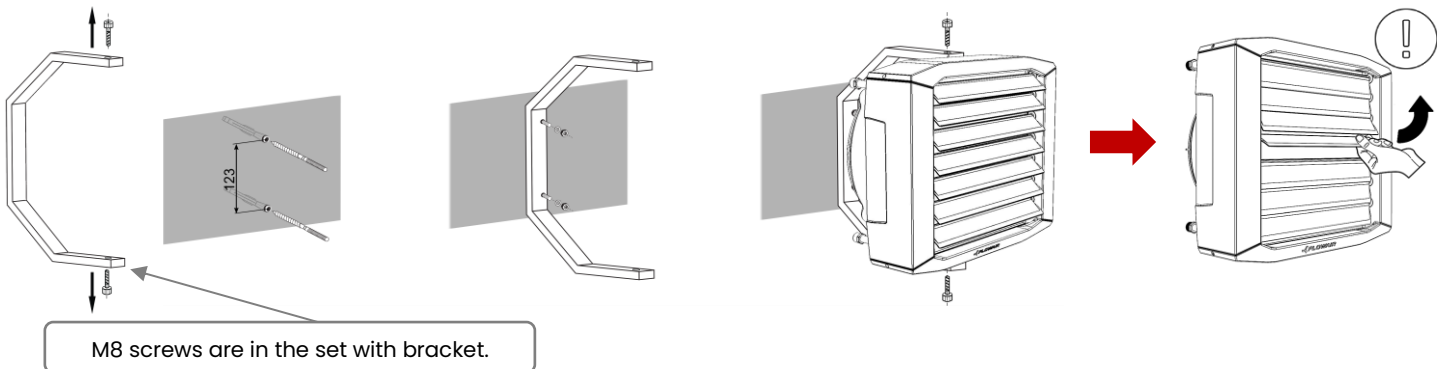

4.3 Z-PROFILES (optional)

Ceiling mounting brackets are optional accessories. They must be installed in the corners of the heater. For this purpose, first remove the screws and then use them to fasten the ceiling brackets. Installation of the brackets in other locations is not permitted.

⊗ WARNING! The unit must be mounted on mounting studs in such a way as to ensure stability and prevent vibrations and changes in position during operation.

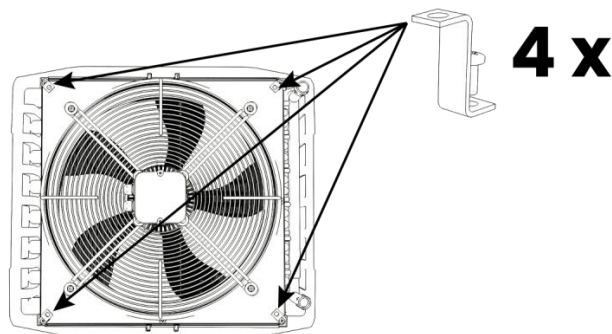

5. CONNECTION DIAGRAMS

5.1 HMI EC CONTROLLER

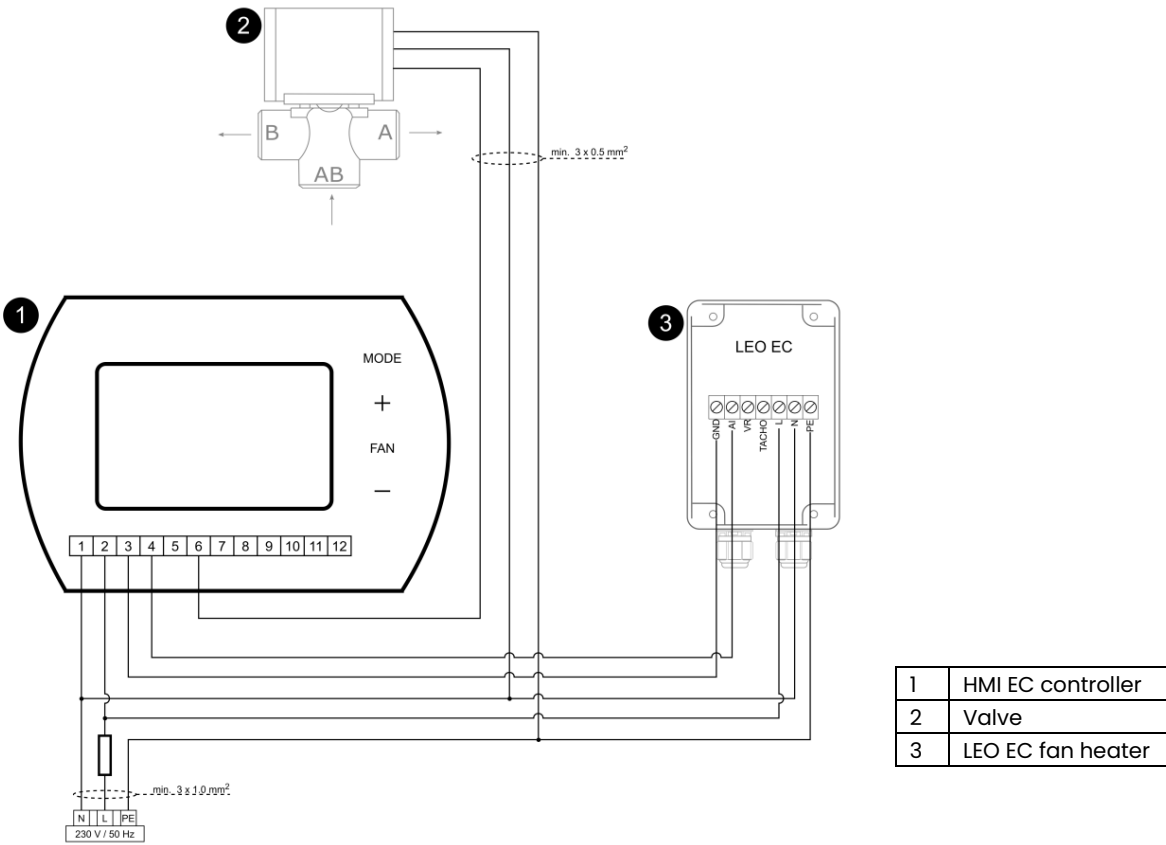

5.2 DRV M CONTROL MODULE

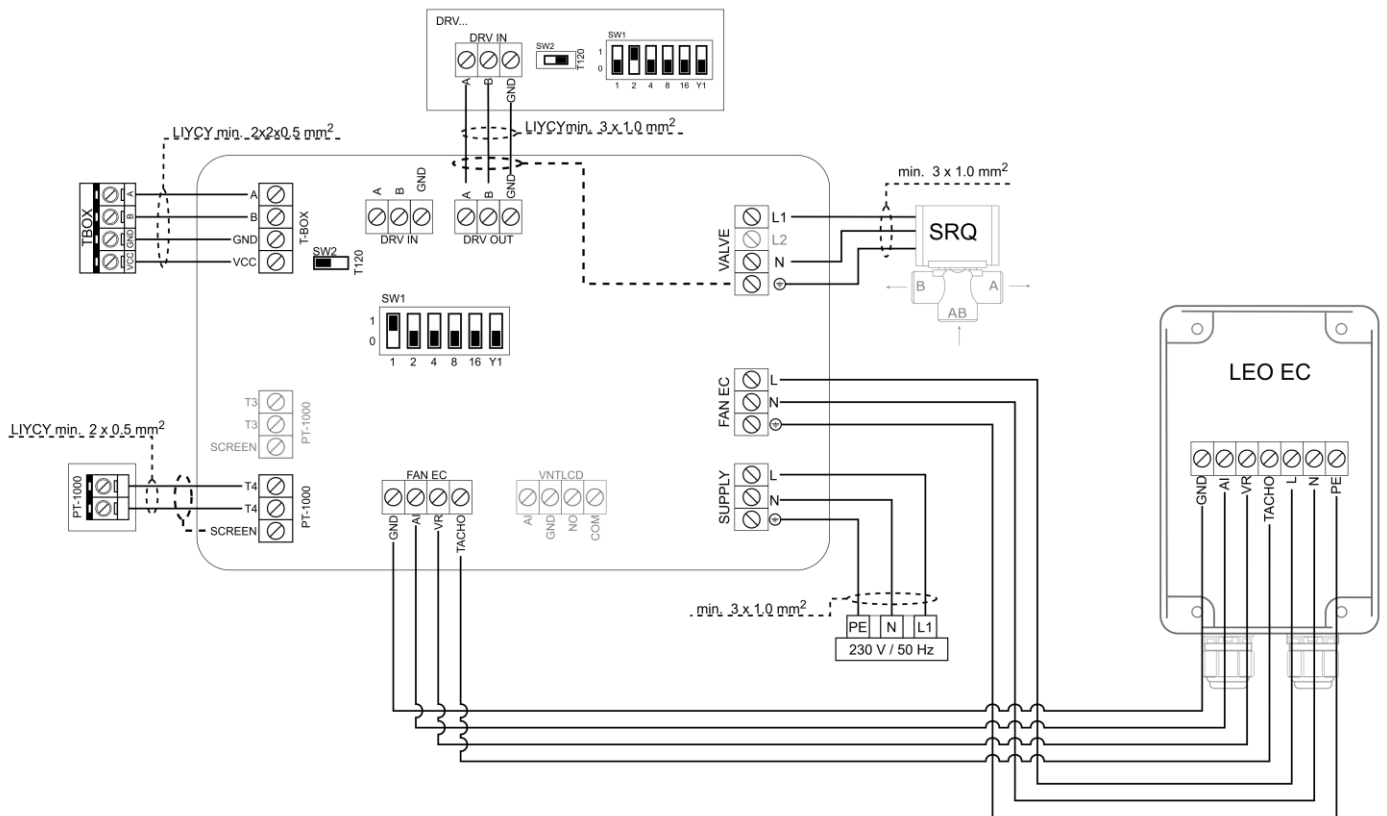

| | |
|---|---------------------|
| Glands | 6 x PG9 + 2 x PG 11 |
| Wires size and type should be chosen by the designer. | |

| DRV no. | | | | | | |
|---------|--------------------------|--------------------------|--------------------------|--------------------------|--------------------------|--------------------------|
| 1 | <input type="checkbox"/> | <input type="checkbox"/> | <input type="checkbox"/> | <input type="checkbox"/> | <input type="checkbox"/> | <input type="checkbox"/> |
| 2 | <input type="checkbox"/> | <input type="checkbox"/> | <input type="checkbox"/> | <input type="checkbox"/> | <input type="checkbox"/> | <input type="checkbox"/> |
| 3 | <input type="checkbox"/> | <input type="checkbox"/> | <input type="checkbox"/> | <input type="checkbox"/> | <input type="checkbox"/> | <input type="checkbox"/> |
| ... | | | | | | |
| 31 | <input type="checkbox"/> | <input type="checkbox"/> | <input type="checkbox"/> | <input type="checkbox"/> | <input type="checkbox"/> | <input type="checkbox"/> |
| | 1 | 2 | 3 | 4 | 5 | 6 |
| | 1 | 2 | 4 | 8 | 16 | Y1 |

When connecting DRV modules to the T-box controller or BMS, you have to binary set addresses on each (each DRV must have individual address) DRV module by DIP-switch SW1. To address modules, check if the power supply is turned off, then set the addresses as shown in the table, then turn on the power supply.

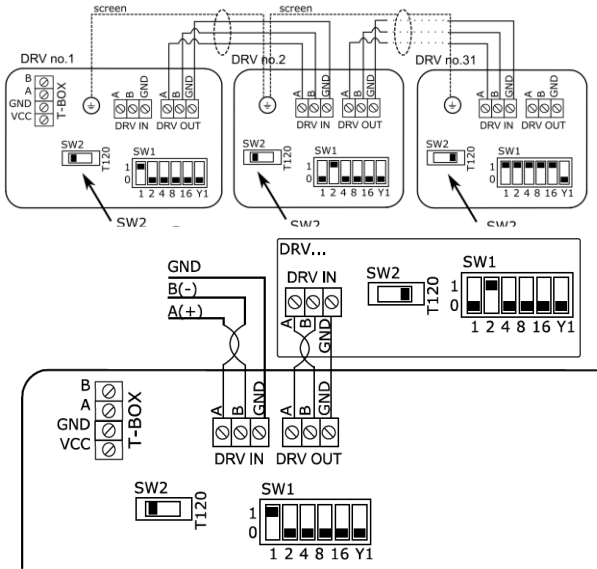

It is possible to connect to 31 modules DRV and control them with one T-box controller

DRV modules can be connected to the BMS (Building Management System).

WARNING  The connections must be carried out with 3-wire (recommended UTP) to connectors DRV IN.

5.3 HYDRAULIC CONNECTION

Detailed hydraulic diagrams of LEO water heaters are available on the website www.flowair.pl in the Documentation section. Below is an example of a hydraulic connection of the LEO water heater.

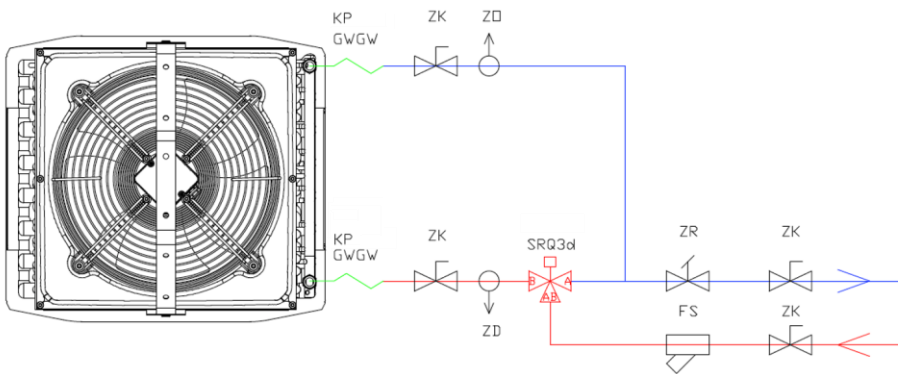

| | |
|---------|----------------------------------|
| KP GWGW | flexible hose (female threads) |
| ZK | shut-off valve |
| ZO | air vent valve |
| ZD | drain valve |
| SRQ3d | 3-way valve with ON/OFF actuator |
| ZR | balancing valve |
| FS | mesh filter |

START-UP AND OPERATION

Guidelines for System Connection

- It is recommended to use flexible hoses on the water exchanger connections.
- It is recommended to install vent valves at the highest point of the system.
- The system should be executed so that, in the case of a failure, it is possible to disassemble the device. For this purpose, it is best to use shut-off valves just by the device.

- The system with the heating medium must be protected against an increase of the heating medium pressure above the permissible value (1.6 MPa).
- While screwing exchanger to pipeline - connecting stubs must be hold by wrench.

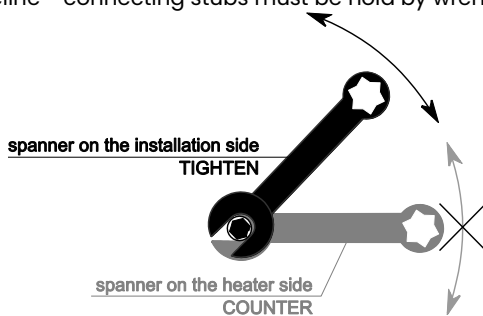

Start Up

- Before installation, check the condition of the device and the fan setting. Do not switch on devices that show signs of damage, or the fan has moved during transport. Before hanging and connecting the device, place it in the target operating position and check that the fan rotates freely (does not rub against other elements). To position the fan, gently remove the fan mounting screws, adjust the fan position, and tighten the mounting screws (torque 3.5 Nm).

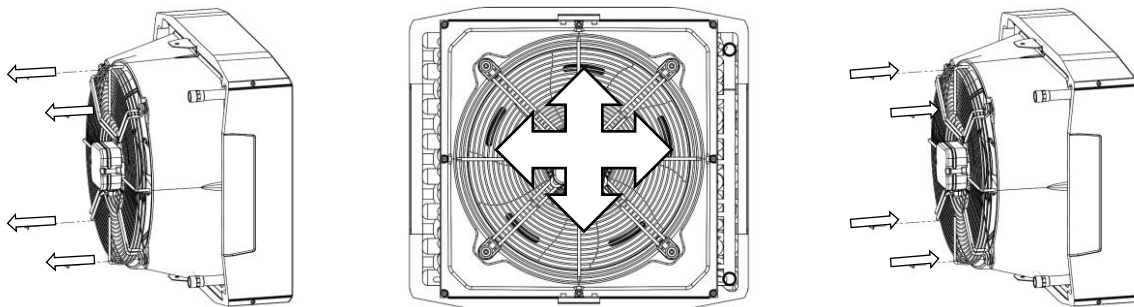

- Before connecting the power supply check the correctness of connection of the fan motor and the controllers. These connections should be executed in accordance with their technical documentation.
- Before connecting the power supply check whether the mains voltage is in accordance with the voltage on the device data plate.
- Before starting the device check the correctness of connection of the heating medium conduits and the tightness of the system.
- The electrical system supplying the fan motor should be additionally protected with a circuit breaker against the effects of a possible short-circuit in the system.
- Starting the device without connecting the ground conductor is forbidden.

Operation

- The device is designed for operation inside buildings, at temperatures above 0°C. In low temperatures (below 0°C) there is a danger of freezing of the medium.



The manufacturer bears no responsibility for damage of the heat exchanger resulting from freezing of the medium in the heat exchanger. If operation of the device is expected at temperatures lower than 0°, then glycol solution should be used as the heating medium, or special automatic systems should be used for protecting against freezing of the medium in the exchanger.

- It is forbidden to place any objects on the heater or to hang any objects on the connecting stubs.
- The device must be inspected periodically. In the case of incorrect operation of the device, it should be switched off immediately.



It is forbidden to use a damaged device. The manufacturer bears no responsibility for damage resulting from the use of a damaged device.

- If it is necessary to clean the heat exchanger, be careful not to damage the aluminium lamellas.
- For the time of performing inspection or cleaning the device, the electrical power supply should be disconnected.
- In case water is drained from the device for a longer period, the heat exchanger tubes should be emptied with compressed air.
- It is not allowed to make any modification in the unit. Any modification causes in warranty loss.

Periodic inspections

To keep proper technical parameters FLOWAIR recommends periodic service (every 6 months) of fan heaters on behalf of the user. During inspections user should:

- Check heat exchanger, if it is filled with dirt or dust. If necessary – use pressurized air stream to clean the exchanger’s lamellas,

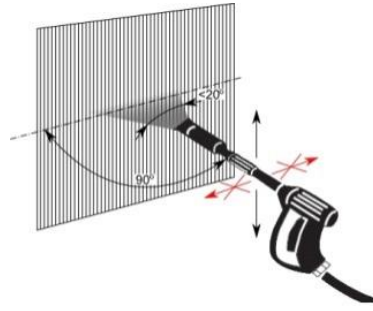

- Check heat exchanger, if it is filled with dirt or dust. If necessary – use pressurized air stream to clean the exchanger’s lamellas,
- Check fan blades, in case of dirt use damp cloth and remove dirt,
- Check bracket installation,
- Check heat exchanger and hydraulic connection correctness,
- Check wires insulation,
- Check power supply,
- Check medium flow,
- Check levelling of the unit.

6. SERVICE AND WARRANTY TERMS

Please contact your dealer to get acquainted with the warranty terms and its limitation.

In the case of any irregularities in the device operation, please contact the manufacturer’s service department.

The manufacturer bears no responsibility for operating the device in a manner inconsistent with its purpose, by persons not authorised for this, and for damage resulting from this!

Made in Poland

Made in EU

Manufacturer: FLOWAIR SP. Z O.O.

ul. Chwaszczyńska 135, 81-571 Gdynia

phone: +48 58 669 82 20

e-mail: info@flowair.pl

www.flowair.com

7. CONFORMITY WITH WEE DIRECTIVE 2012/19/UE

Running a business without harming the environment and observing the rules of proper handling of waste electrical and electronic equipment is a priority for FLOWAIR.

The symbol of the crossed out wheeled bin placed on the equipment, packaging or documents attached means that the product must not be disposed of with other wastes. It is the responsibility of the user to hand the used equipment to a designated collection point for proper processing. The symbol means while the equipment was placed on the market after August 13, 2005.



For information on the collection system of waste electrical and electronic equipment, please contact the distributor.

REMEMBER:



Do not dispose of used equipment together with other waste! There are financial penalties for this. Proper handling of used equipment prevents potential negative consequences for the environment and human health. At the same time, we save the Earth’s natural resources, reusing resources obtained from the processing of equipment.

DECLARATION OF CONFORMITY EU
СОТВЕТСТВИИ EU / CONFORMITEITSVERKLARING EU / EU MEGFELELŐSÉGI
NYILATKOZAT / DECLARATIE DE CONFORMITATE EU

④ **FLOWAIR SP. Z O.O.**

ul. Chwaszczyńska 135, 81-571 Gdynia

e-mail: info@flowair.pl www.flowair.com



① Wodne nagrzewnice powietrza / water heating unit

③ 29.01.2024

② LEO EC;



DEKLARACJA ZGODNOŚCI UE / DECLARATION OF CONFORMITY EU

PL/EN

④ Niniejszym deklarujemy, iż wodne nagrzewnice powietrza / FLOWAIR hereby confirms that fan heaters:

- ② LEO S2 EC, LEO S3 EC, LEO S3 NP EC
- LEO L2 EC, LEO L3 EC, LEO L3 NP EC,
- LEO XL2 EC, LEO XL3 EC, LEO XL3 NP EC

⑤ zostały wyprodukowane zgodnie z wymaganiami następujących Dyrektyw Unii Europejskiej / were produced in accordance to the following Europeans Directives:

1. **2014/30/UE** Kompatybilności elektromagnetycznej (EMC) / Electromagnetic Compatibility (EMC)
2. **2006/42/WE** Maszynowej / Machinery
3. **2014/35/UE** Niskonapięciowe wyroby elektryczne (LVD) / Low Voltage Electrical Equipment (LVD)

⑥ oraz zharmonizowanymi z tymi dyrektywami normami /and harmonized norms ,with above directives:

| | |
|------------------------------|--|
| PN-EN ISO 12100:2012 | Bezpieczeństwo maszyn - Ogólne zasady projektowania - Ocena ryzyka i zmniejszanie ryzyka / Safety Of Machinery - General Principles For Design - Risk Assessment And Risk Reduction |
| PN-EN 60335-1:2012 | Elektryczny sprzęt do użytku domowego i podobnego - Bezpieczeństwo użytkowania - Część 1: Wymagania ogólne/ Household and similar electrical appliances - Safety - Part 1: General requirements |
| PN-EN 60335-2-30:2010 | Elektryczny sprzęt do użytku domowego i podobnego -Bezpieczeństwo użytkowania - Część 2-30: Wymagania szczegółowe dotyczące ogrzewaczy pomieszczeń/ Household and similar electrical appliances - Safety - Part 2-30: Particular requirements for room heaters |
| PN-EN 61000-6-2:2008 | Kompatybilność elektromagnetyczna (EMC) - Część 6-2: Normy ogólne - Odporność w środowiskach przemysłowych / Electromagnetic compatibility (EMC). Generic standards. Immunity for industrial environments |

③ 29.01.2024

⑦ Product Manager

EPECON

Distributör:

EPECON AB

Stockholm - kontor och showroom
Hovslagarevägen 2
192 54 Sollentuna

Helsingborg - kontor och showroom
Florettgatan 22A
SE-254 67 Helsingborg

 **FLOWAIR**
intelligent air flow

Tillverkare:

FLOWAIR Sp. z o.o.

Chwaszczyńska 135,
81-571 Gdynia

www.flowair.com

